



12 tons

P12BMR / P12MR ELECTRO-HYDRAULIC PRESS AUTOMATIC DOUBLE-SPEED WITH FAST APPROACH

Heavy-duty electro-hydraulic press, **entirely laser-cut**. Extra- solid structure without welded points in frontal frame.

Power unit with submerged motor **400V 50-60 Hz**, automatic double-speed pump calibrated at **20 Bar** (from fast approach to working speed) and a pump to adjust pressure through a knob. Fitted with a safety valve that prevents machine overpressure.

A manometer mounted on the distributor indicates working pressure.

Optional available on request: **V blocks, plates, electric speed control device, perimeter protection and limit switch.**

Technical data			
	UM	P12MR	P12BMR
Max capacity	[ton]	12	12
Approaching speed	[mm/min]	1800	1800
Working speed	[mm/min]	750	750
Max capacity in fast mode	[l/min]	6	6
Max capacity in slow mode	[l/min]	2.5	2.5
Cylinder stroke	[mm]	300	300
Cylinder bore center	[mm]	65	65
Stem diameter	[mm]	40	40
Shank diameter	[mm]	M14	M14
Tank capacity	[litri]	30	30
Max pressure	[bar]	350	350
Tension	[V]	400	400
Frequency	[Hz]	50-60	50-60
Motor power	[kW]	1.5	1.5
Max power adsorption	[A]	2.8	2.8
Weight	[kg]	150	140

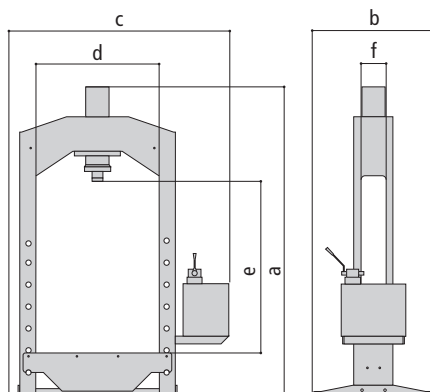

Dimensions						
	a	b	c	d	e	f
P12BMR	1200	530	1100	510	400	80
P12MR	1840	530	1100	510	1040	80

