



110 tons

## P110MR ELECTRO-HYDRAULIC PRESS AUTOMATIC DOUBLE-SPEED WITH FAST APPROACH

Heavy-duty electro-hydraulic press, **entirely laser-cut**. Extra- solid structure without welded points. Power unit with submerged motor **400V 50-60 Hz**, automatic double-speed pump calibrated at **20 Bar** (from fast approach to working speed) and a pump to adjust pressure through a knob.

Fitted with a safety valve that prevents machine overpressure. A manometer mounted on the distributor indicates working pressure. Optional available on request: **V blocks, plates, electric speed control device, perimeter protection and limit switch.**

Technical data		
	UM	P110MR
Max capacity	[tons]	110
Approaching speed	[mm/min]	1600
Working speed	[mm/min]	161
Max capacity in fast mode	[l/min]	48
Max capacity in slow mode	[l/min]	5
Cylinder stroke	[mm]	300
Cylinder bore center	[mm]	200
Stem diameter	[mm]	110
Shank diameter	[mm]	M30
Tank capacity	[litri]	50
Max pressure	[bar]	350
Tension	[V]	400
Frequency	[Hz]	50-60
Motor power	[kW]	3
Max power adsorption	[A]	7.3
Weight	[kg]	1100

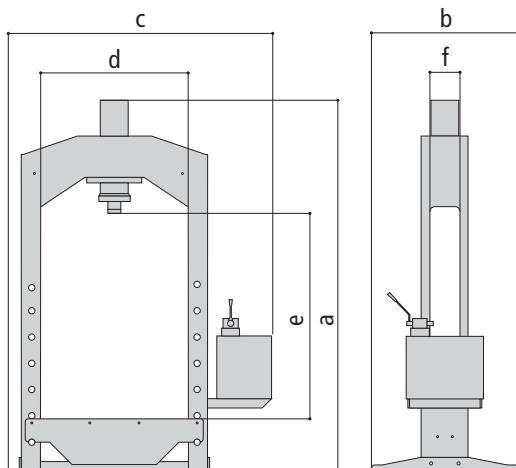
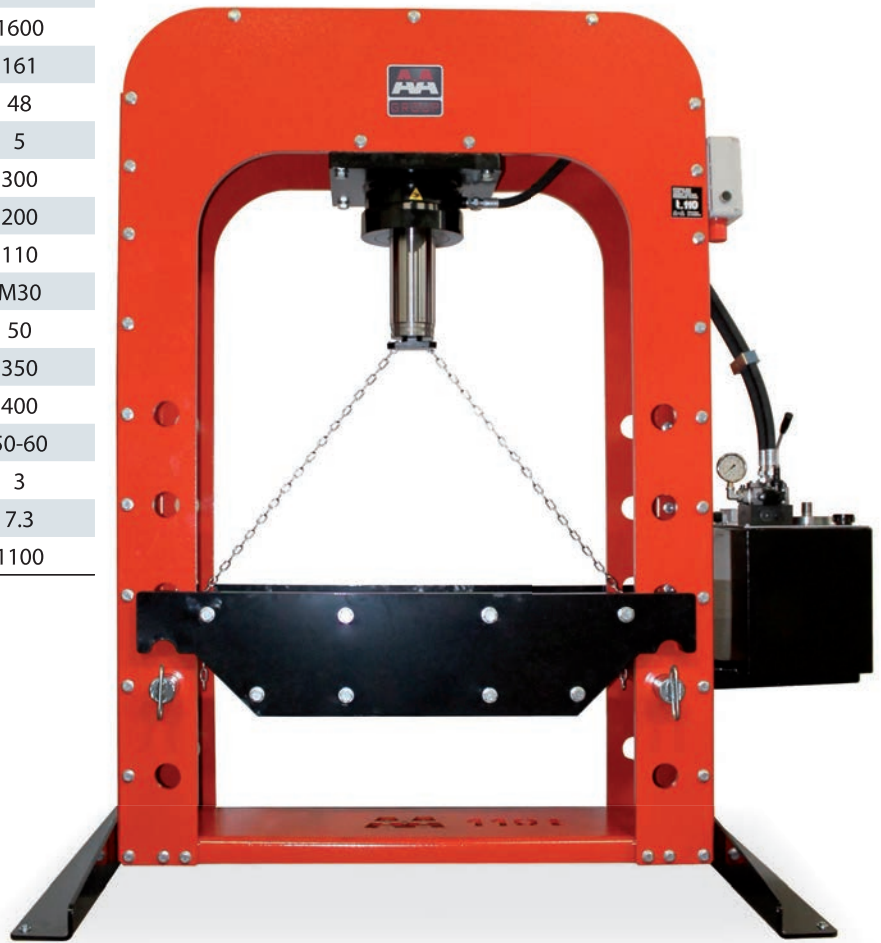

Dimensions						
	a	b	c	d	e	f
P110MR	2030	1280	1880	1004	1060	280