

IT900

BATTERY-POWERED INDOOR ELECTRIC TUG
TO PULL LOADS **UP TO 3000 KG***

ZERO EMISSIONS

QUIET

LOW MAINTENANCE



Tilting tiller with micro safety switch and automatic return to the rest position



Butterfly throttle, easy speed control with one hand, with hare / turtle switch in the tiller head



Battery charger on board, display with light indication of charge status



Pivoting wheel allows a minimum of space to steer

MADE IN ITALY

The IT 900 is a towing equipment, with three wheels and tiller steering. It is designed to easily move trailer trolleys and other containers on wheels, in safety and comfort, reducing physical stress and improving productivity. Many configurations are possible by choosing among different types of batteries and tires. It can be fitted with several hooks that make the standard product adaptable to many uses.

ALITRAK[®]
ELECTRIC MINDED

www.alitrak.com

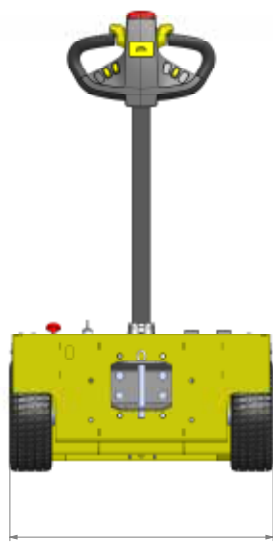

735 mm

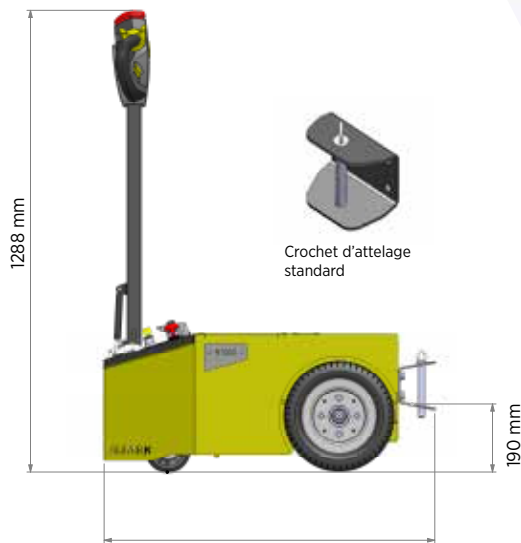

1288 mm

Crochet d'attelage standard

190 mm

923 mm



ALITRAK
ELECTRIC MINDED

www.alitrak.com

FEATURES

Equipment body	3 wheels
Driving wheels on differential	Garden type polyurethane filled
Driving control type	Tilt tiller
Accelerator	Butterfly type
Hook height (3)	About 135 mm, 190 mm, 245 mm
Battery charger	On board, 13A High Frequency
Dashboard display IT1200	Remaining battery charge, Remaining battery charge, equipment failures and Hour meter
Parking brake	Electromagnetic with the possibility of release
AGM Batteries	2 x 12V/85 Ah C20
Electric motor IT900 IT1200	24V/900 watt S1 24V/1200 watt AC S2 60 min.
Product net weight	175 kg abt

PERFORMANCE

Weight movement capacity on flat surface up to*	3000 Kg
Pulling speed	
Fast	5 Km/h abt
Slow	2,5 Km/h abt
Pushing speed	
Fast	3 Km/h abt
Slow	1,5 km/h abt
Battery recharging time	8 hours abt

*The weight movement capacity is an indication., that can change with different machine fittings and working conditions (type of ground,wheel type,use of ballast,etc.)

Features shown are subject to change without notice

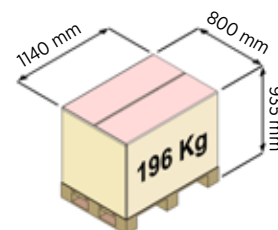

ACCESSORIES



Support on the tug top with hook



Trailer mount and ball



Different hook types



Clamp for trailer trolleys



Squared tube hook



Ballast support



Ballast



Flashing light



Anti dumping wheel frame with additional hook heights



Different battery types